

May.1.2017 Copyright 2017 HIROSE ELECTRIC CO., LTD. All Rights Reserved.

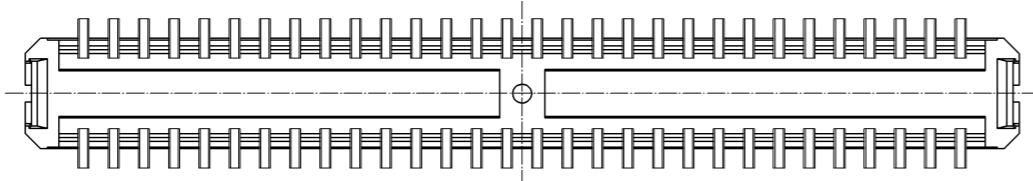
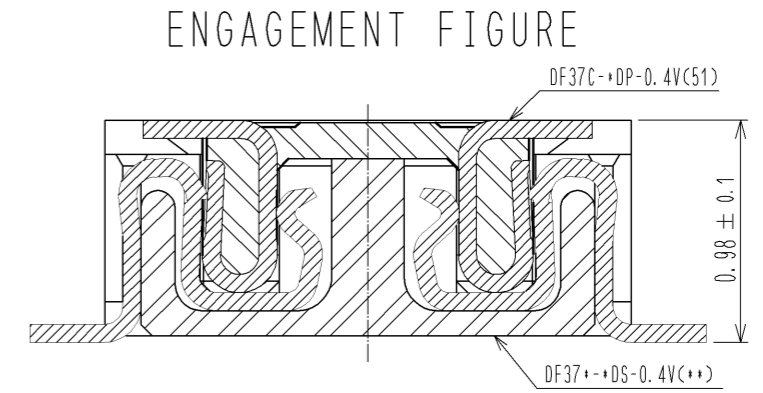
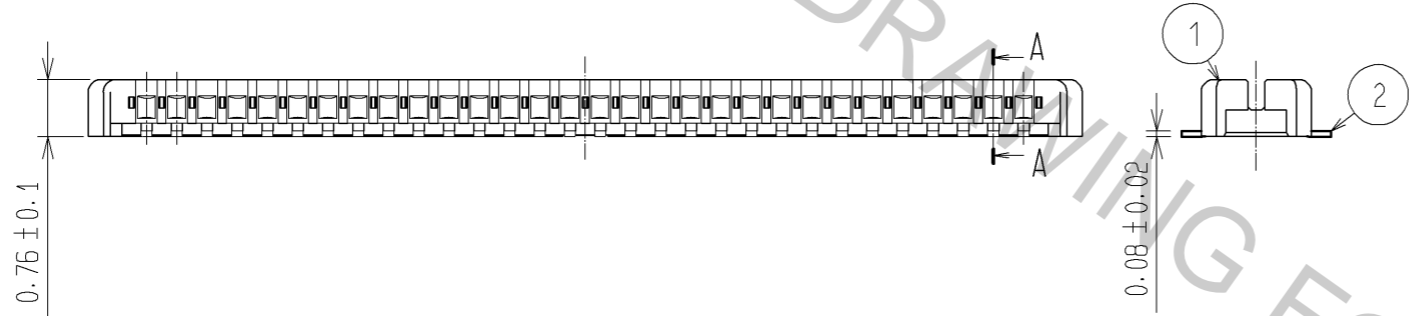
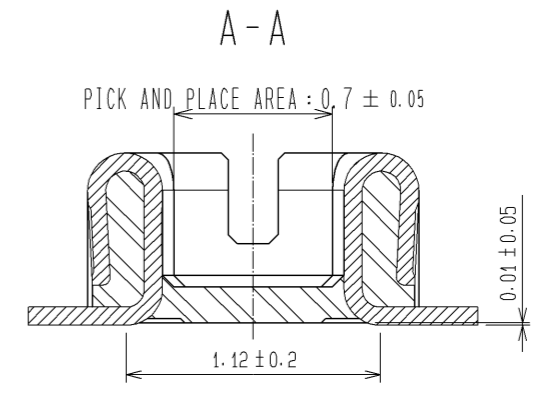
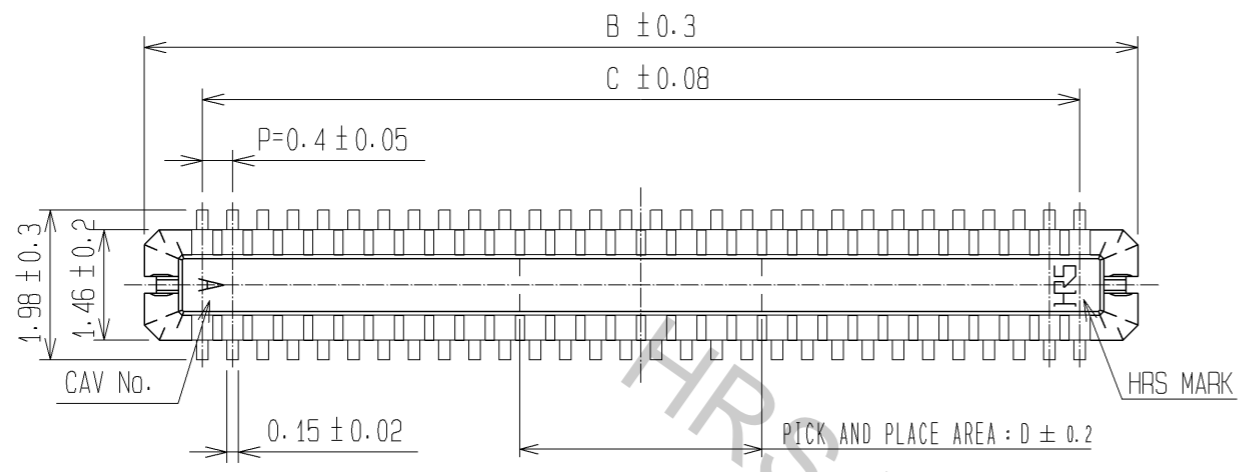

PART No.	CL No.	B	C	D
DF37C-10DP-0.4V(51)	CL684-3039-5-51	3.14	1.6	0.8
DF37C-16DP-0.4V(51)	CL684-3058-0-51	4.34	2.8	1.2
DF37C-20DP-0.4V(51)	CL684-3024-8-51	5.14	3.6	1.6
DF37C-24DP-0.4V(51)	CL684-3025-0-51	5.94	4.4	2.0
DF37C-30DP-0.4V(51)	CL684-3026-3-51	7.14	5.6	2.0
△ DF37C-34DP-0.4V(51)	CL684-3085-2-51	7.94	6.4	2.4
DF37C-40DP-0.4V(51)	CL684-3027-6-51	9.14	7.6	2.4
△ DF37C-44DP-0.4V(51)	CL684-3089-3-51	9.94	8.4	2.8
DF37C-50DP-0.4V(51)	CL684-3028-9-51	11.14	9.6	2.8
DF37C-60DP-0.4V(51)	CL684-3029-1-51	13.14	11.6	3.2
△ DF37C-70DP-0.4V(51)	CL684-3030-0-51	15.14	13.6	3.6
△ DF37C-74DP-0.4V(51)	CL684-3073-3-51	15.94	14.4	4.0

NOTE 1. ALL LEADS CO-PLANARITY SHALL BE 0.1 mm MAX.  
 2 CONTACT PLATING SPECIFICATIONS.  
 CONTACT AREA : GOLD 0.05 μm MIN  
 SMT LEAD : GOLD 0.05 μm MIN  
 UNDER PLATING : NICKEL 1 μm MIN  
 (SURFACE : SEALING)

2	PHOSPHOR BRONZE	2	5	PS	BLACK, PLASTIC REEL			
1	LCP	BLACK, UL94V-0	4	POLYESTER	CLEAR, COVER TAPE			
			3	PS	CLEAR, EMBOSSED CARRIER TAPE			
NO.	MATERIAL	FINISH, REMARKS	NO.	MATERIAL	FINISH, REMARKS			
UNITS	mm	SCALE	FREE	COUNT	DESCRIPTION OF REVISIONS	DESIGNED	CHECKED	DATE
				12	DIS-H-005512	KR. AJITO	TS. MIYAZAKI	11.02.09
APPROVED : MO. NAKAMURA		07.01.29		DRAWING NO.		EDC3-314974-01		
CHECKED : KH. IKEDA		07.01.29		PART NO.		DF37C- *DP-0.4V(51)		
DESIGNED : KY. MIDORIKAWA		07.01.29		CODE NO.				
DRAWN : KY. MIDORIKAWA		07.01.29						

◆ RECOMMENDED PCB LAYOUT (MOUNTING SURFACE SIDE)

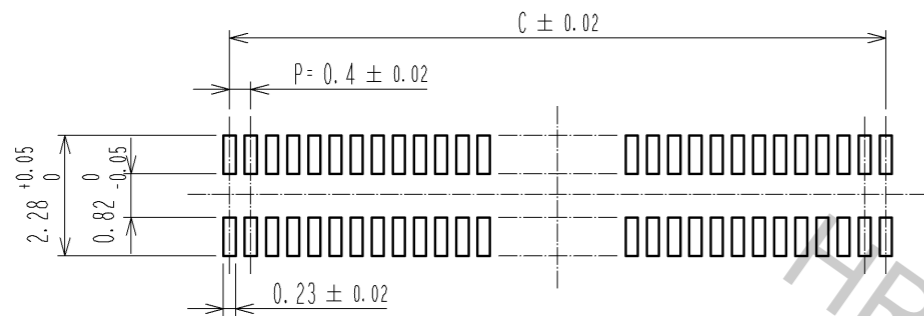

◆ RECOMMENDED METAL MASK DIMENSIONS  
METAL MASK THICKNESS : 0.12mm

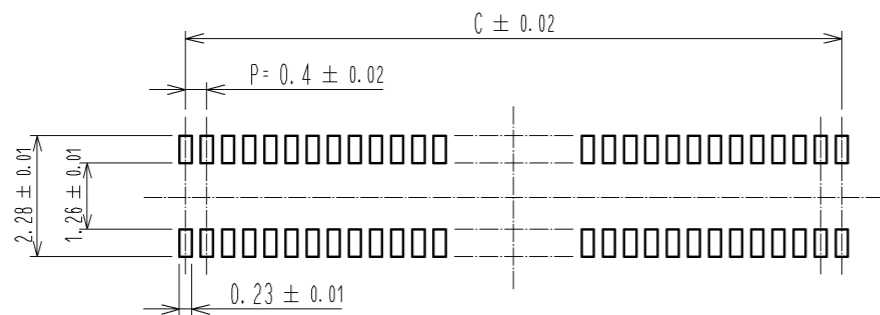

◆ RECOMMENDED METAL MASK DIMENSIONS  
METAL MASK THICKNESS : 0.1mm

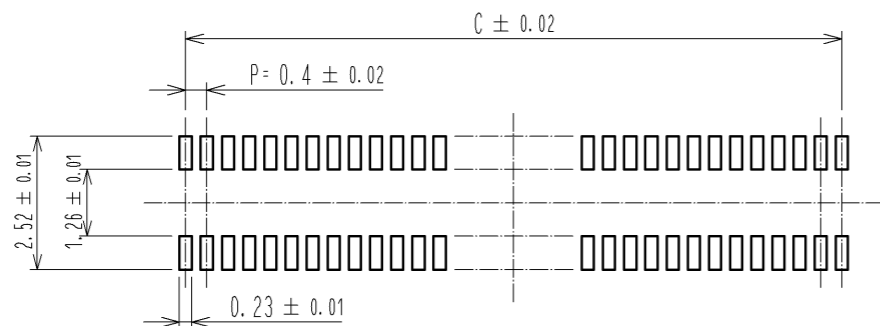

③ RECOMMENDED REFLOW TEMPERATURE PROFILE USING LEAD-FREE SOLDER PASTE.

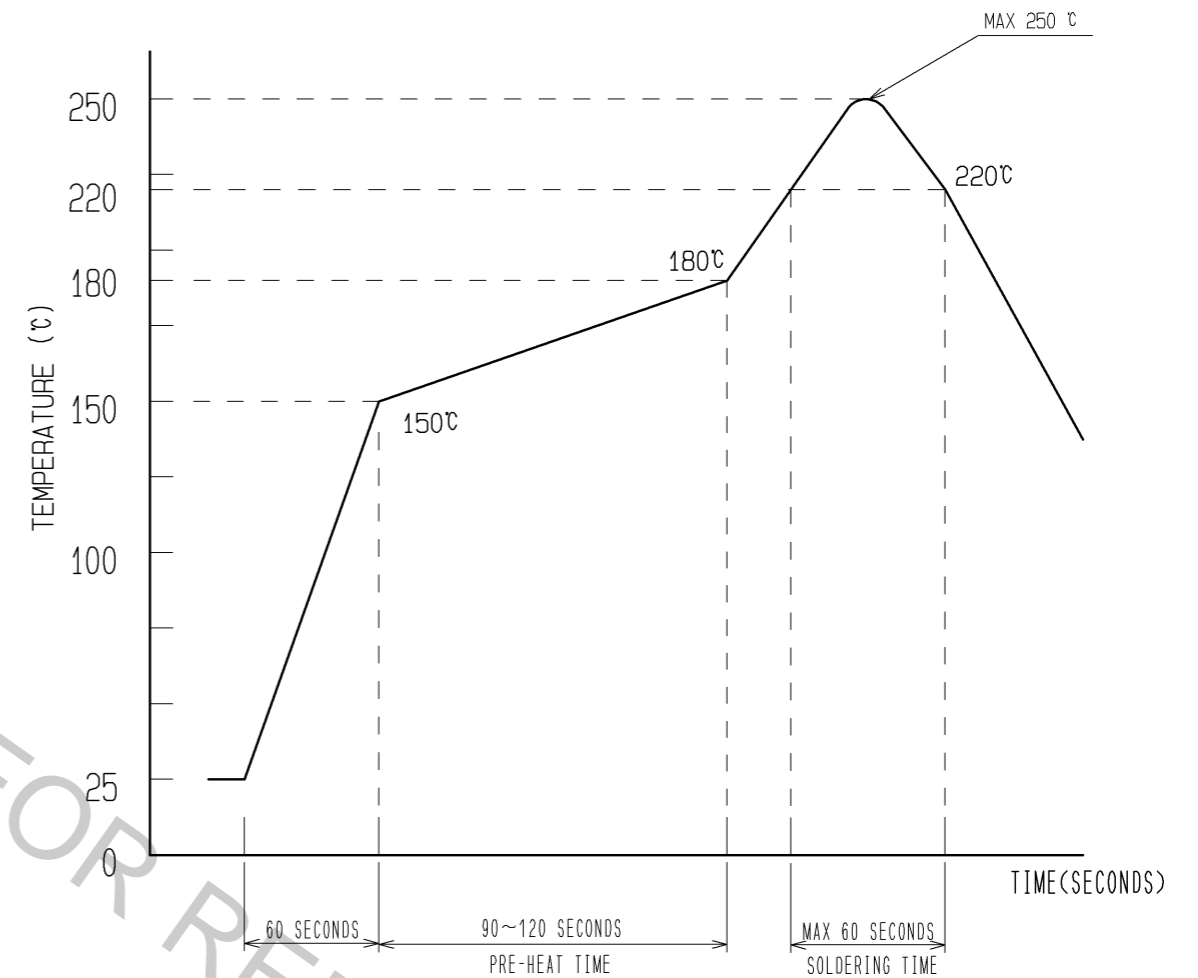

- 1) REFLOW TIME  
REFLOW METHOD: IR REFLOW  
NUMBER OF REFLOW CYCLES: 2 CYCLES MAX.  
DURATION ABOVE 220 °C: 60 SEC. MAX.  
(PEAK TEMPERATURE: 250°C MAX.)
- 2) PRE-HEAT TIME  
PRE-HEAT TEMPERATURE(MIN) : 150 °C  
PRE-HEAT TEMPERATURE(MAX) : 180 °C  
PRE-HEAT TIME : 90~120 sec.

PART No.	C
DF37C-10DP-0.4V(51)	1.6
DF37C-16DP-0.4V(51)	2.8
DF37C-20DP-0.4V(51)	3.6
DF37C-24DP-0.4V(51)	4.4
DF37C-30DP-0.4V(51)	5.6
△ DF37C-34DP-0.4V(51)	6.4
△ DF37C-40DP-0.4V(51)	7.6
△ DF37C-44DP-0.4V(51)	8.4
△ DF37C-50DP-0.4V(51)	9.6
△ DF37C-60DP-0.4V(51)	11.6
△ DF37C-70DP-0.4V(51)	13.6
△ DF37C-74DP-0.4V(51)	14.4

③ THIS TEMPERATURE PROFILE IS PER THE CONDITIONS SHOWN ABOVE. ADDITIONAL FACTORS, SUCH AS SOLDER PASTE TYPE, PCB SIZE AND OTHER MOUNTED COMPONENTS COULD AFFECT THE PROFILE. THEREFORE, A THOROUGH EVALUATION OF MOUNTING CONDITION IS REQUIRED PRIOR TO PRODUCTION. TEMPERATURE IS MEASURED AT CONTACT LEAD.

<b>HRS</b>	DRAWING NO.	EDC3-314974-01
	PART NO.	DF37C-*DP-0.4V(51)
	CODE NO.	
		2/3

EMBOSSED CARRIER TAPE PACKAGING (FREE SIZE)

◆ LESS THAN 70 POS.

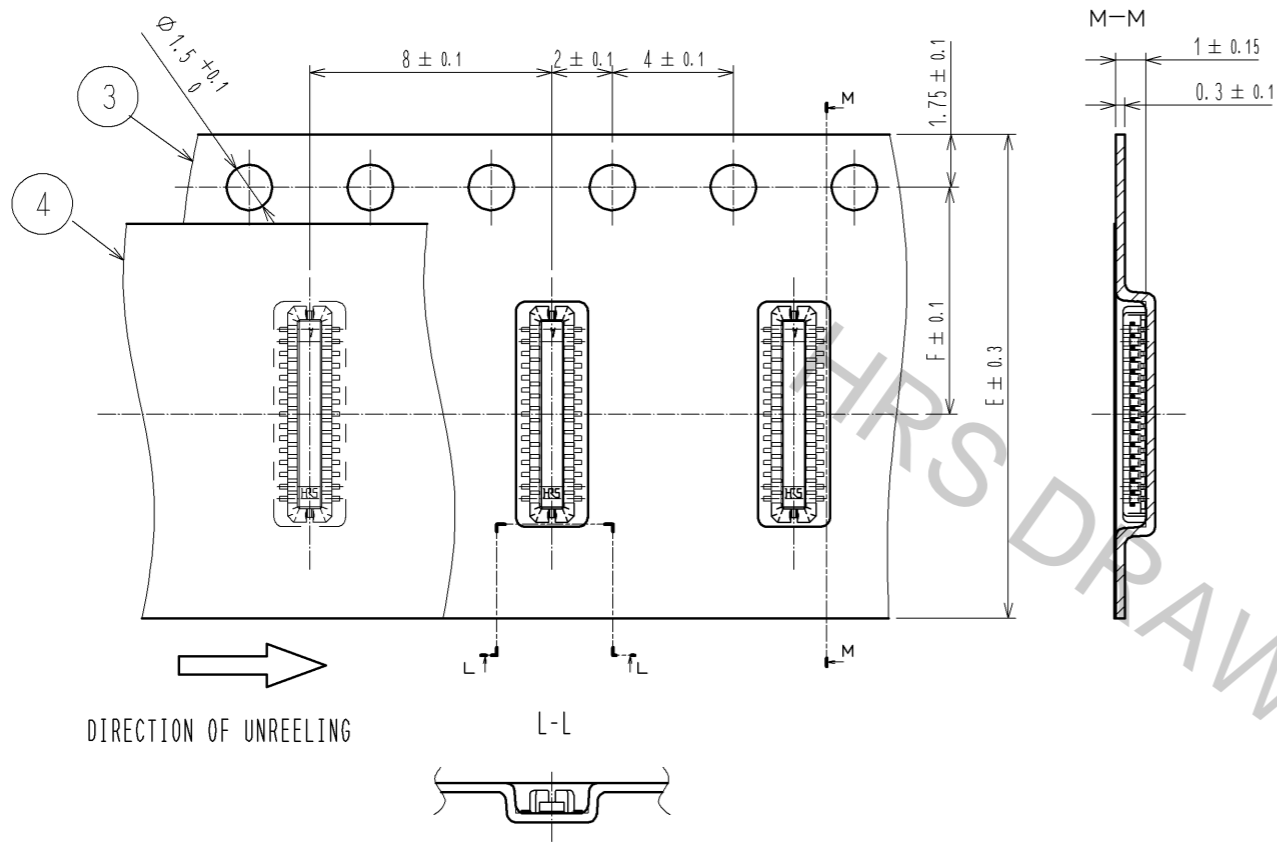

EMBOSSED CARRIER TAPE PACKAGING (FREE SIZE)

◆ 74 POS.

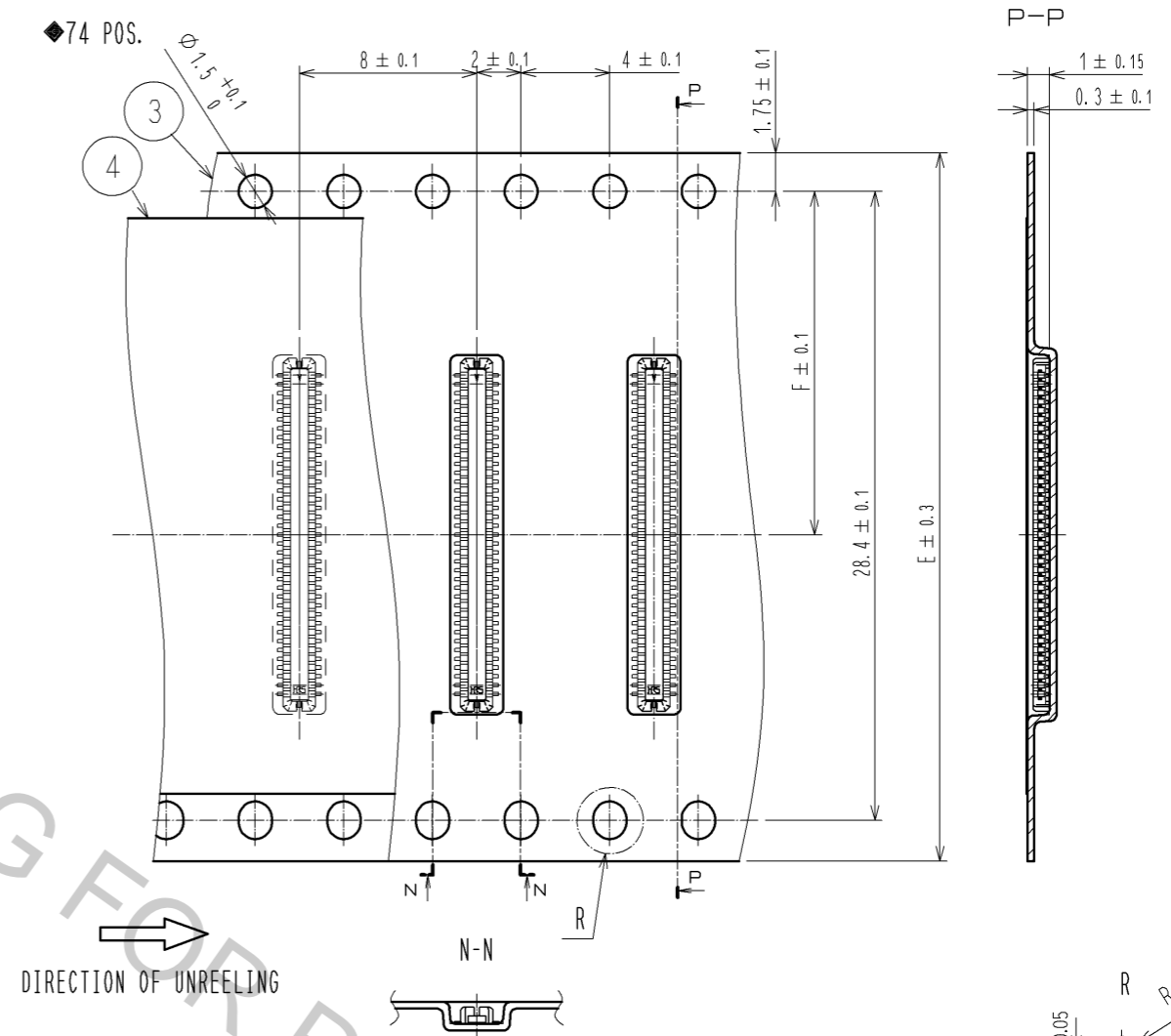

STYLE AND DIMENSION OF REEL (FREE SIZE)

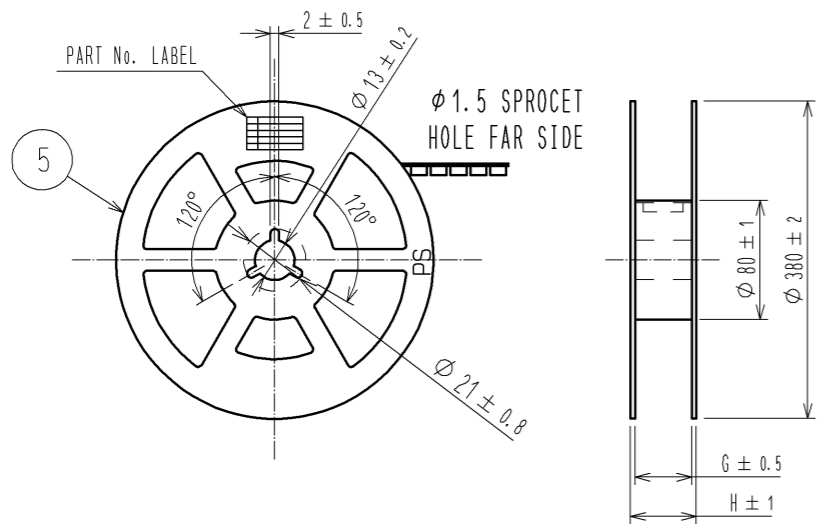

7 DETAIL OF PART No. LABEL

SUPPLIER	ヒロセ電機 (株)
QUANTITY	8000個
PART NO.	DF37C-+DP-0.4V(51)
CODE NO.	** ** *
DATE OF MANUFACTURED	年 月 日
製造年月日	年 月 日
製品コード	** ** *
製品名	DF37C-+DP-0.4V(51)
数量	8000個
納入者	ヒロセ電機 (株)

PART No.	E	F	G	H
DF37C-10DP-0.4V(51)	12	5.5	13.5	17.5
DF37C-16DP-0.4V(51)	16	7.5	17.5	21.5
DF37C-20DP-0.4V(51)	16	7.5	17.5	21.5
DF37C-24DP-0.4V(51)	16	7.5	17.5	21.5
DF37C-30DP-0.4V(51)	16	7.5	17.5	21.5
DF37C-34DP-0.4V(51)	16	7.5	17.5	21.5
DF37C-40DP-0.4V(51)	24	11.5	25.5	29.5
DF37C-44DP-0.4V(51)	24	11.5	25.5	29.5
DF37C-50DP-0.4V(51)	24	11.5	25.5	29.5
DF37C-60DP-0.4V(51)	24	11.5	25.5	29.5
DF37C-70DP-0.4V(51)	24	11.5	25.5	29.5
DF37C-74DP-0.4V(51)	32	14.2	33.5	37.5

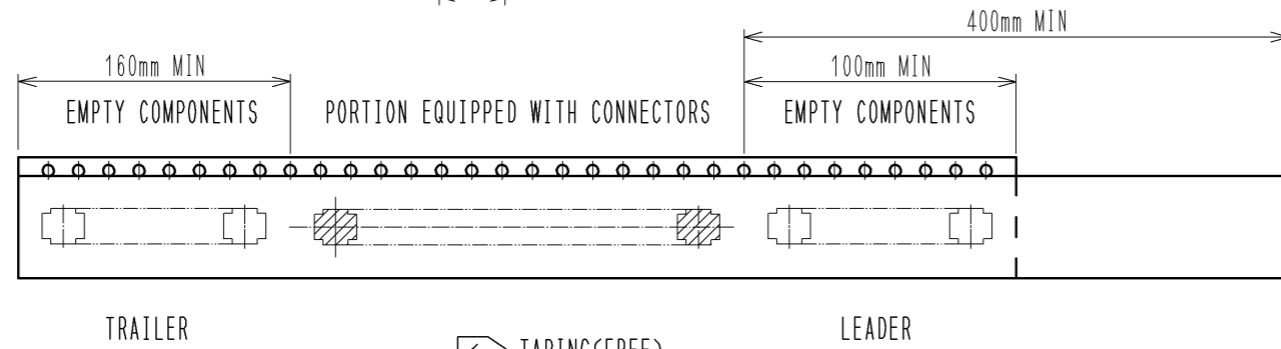

NOTES 4. PER REEL 8000 CONNECTORS.

5. THE DIMENSIONS IN PARENTHESES ARE FOR REFERENCE.

6 REFER TO JIS C 0806(PACKING OF COMPONENTS FOR AUTOMATIC HANDLING)

7 DETAIL OF PART No. LABEL IS WRITTEN IN JAPANESE.

<b>HRS</b>	DRAWING NO.	EDC3-314974-01
	PART NO.	DF37C-+DP-0.4V(51)
	CODE NO.	

3/3